

## Taping of Diodes 2

### AXIAL LEAD COMPONENTS

Diodes and rectifiers with axial leads are normally delivered in taped form according to IEC 286-1 (see figure 1). The cathode side is designated by a colored tape. Taped devices are normally delivered in ammo boxes (ammo pack).

Delivery on reels is available on request.

Quantities per box dimensions 264 (L) x 146 (H) x 73 (W)

PACKAGE	AVAILABLE PACKAGING		
	10" TAPE AND REEL	14" TAPE AND REEL	AMMO PACK #1
	QUANTITY/REEL	QUANTITY/REEL	QUANTITY/BOX
DO35		10 000	10 000

TAPING SPECIFICATIONS DO35 PACKAGE		
DESCRIPTION	SYMBOL	SPECIFICATION (mm)
Component pitch	A	$5.0 \pm 0.5$
Devices with diameter	d	$< 4.5$
Component pitch	A'	$10 \pm 0.5$
Devices with diameter	d'	$> 4.5$
Inside tape spacing	B	$52 + 2 \text{ mm} - 1 \text{ mm}$
Lead to lead eccentricity	ID1-D2I	1.4 max.
Lead extension	K	0
Lead bending	M	1.2 max.
Cumulative pitch	P	2.0 per 10 pitch
Exposed adhesive	S	0.8 max.
Tape width	T	$6.0 \pm 0.4$
Tape leader	Beginning and end of reel or ammo pack	
Empty spaces	Consecutive missing components not allowed	
Polarity marking	All polarized components shall be oriented in the same direction. The cathode tape shall be colored, and anode tape shall be white or light beige.	

#### Note

Allowable deviation above 10 taped steps  $\pm 2 \text{ mm}$

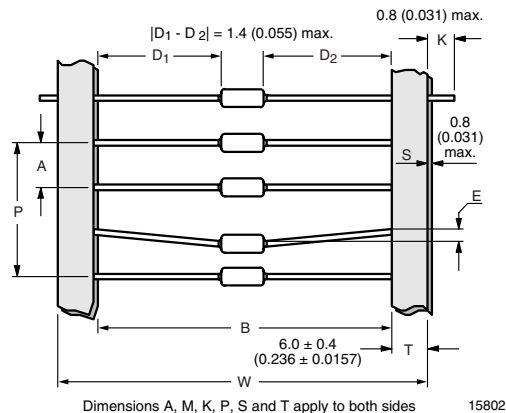

Fig. 1

## AMMO PACK #1 SPECIFICATION DO35 PACKAGES

DESCRIPTION	SYMBOL	SPECIFICATION	
		INCHES	MILLIMETERS
Length	A	10.25 ± 0.2	260 ± 5.0
Width	B	2.75 ± 0.2	70 ± 5.0
Height	C	5.75 ± 0.65	146 ± 16

**Note**

Material: corrugated board (neutral)

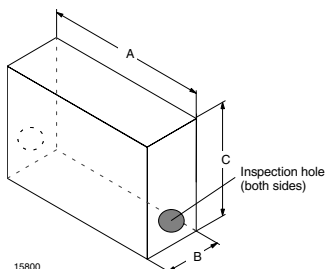

Fig. 2

REEL SPECIFICATION		
DESCRIPTION	SYMBOL	REEL SIZE
		14" DO35
Arbor hole diameter	D <sub>0</sub>	30 ± 1 mm
Core diameter	D <sub>1</sub>	80 ± 1 mm
Reel diameter	D <sub>2</sub>	355 mm
Drive hole diameter	D <sub>3</sub>	8 ± 0.5 mm
Reel width	W <sub>1</sub>	73 mm
Drive/arbor hole spacing	W <sub>2</sub>	26 ± 0.5 mm
Core material		Carton
Reel material		Carton

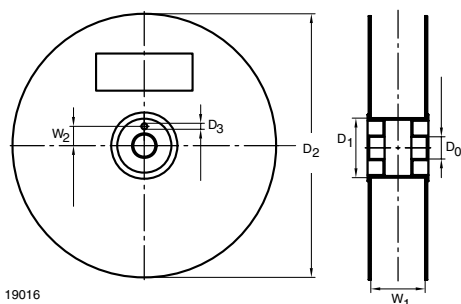

Fig. 3

## TAPE AND REEL SURFACE-MOUNTED DEVICES (SMDs)

SMDs are normally delivered taped on blister tape and reeled according to IEC 286-3. The mounting side of the component is oriented to the bottom side of the tape. For components with two terminations, the cathode side is oriented to the sprocket hole. For components in SOT23 package, the side from which one single termination emerges is oriented to the sprocket hole. Components can be delivered either on 180 mm or on 330 mm reels. For quantities per reel, see below.

CASE TYPE	SUFFIX	QUANTITY	REEL SIZE IN mm (DIAMETER)	TAPE WIDTH IN mm
DO214AC	TR	1500	180	12
	TR3	6000	330	12
MicroMELF	TR	2500	180	8
	TR3	10 000	330	8
MiniMELF SOD80	GS08	2500	180	8
	GS18	10 000	330	8
QuadroMELF SOD80	GS08	2500	180	8
	GS18	10 000	330	8
SMF (DO219AB)	GS08	3000	180	8
	GS18	10 000	330	8
SOD123	GS08	3000	180	8
	GS18	10 000	330	8
SOD323	GS08	3000	180	8
	GS18	10 000	330	8
SOD523	GS08	3000	180	8
	GS18	10 000	330	8
SOT23	GS08	3000	180	8
	GS18	10 000	330	8
SOT323	GS08	3000	180	8
	GS18	10 000	330	8

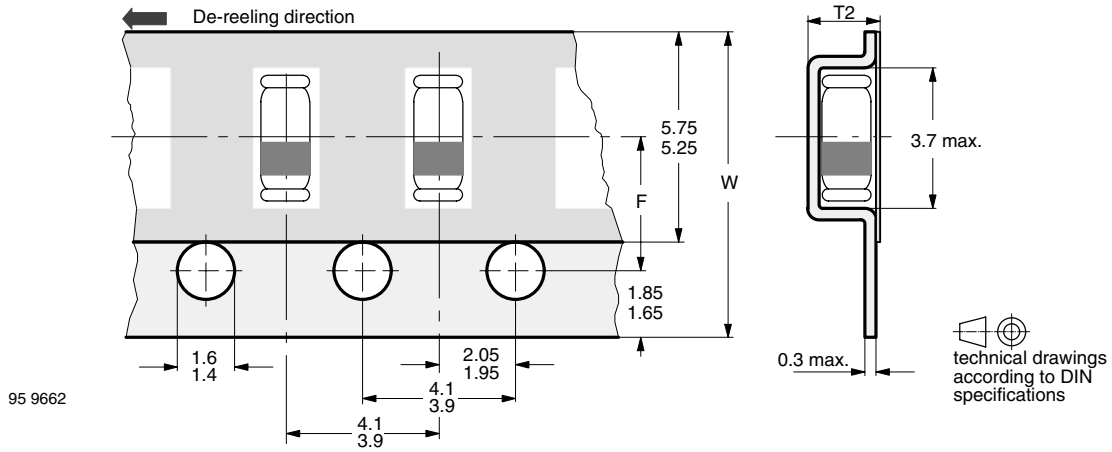

Fig. 4 -

PACKAGES	DIMENSIONS (mm)			
	W	F	T2	B
MiniMELF SOD80, QuadroMELF SOD80, MicroMELF, SOD123, SOD323, SOD523, SOT23, SOT323	8 ± 0.3	3.5 ± 0.05	2.5 max.	8.4 to 10.4

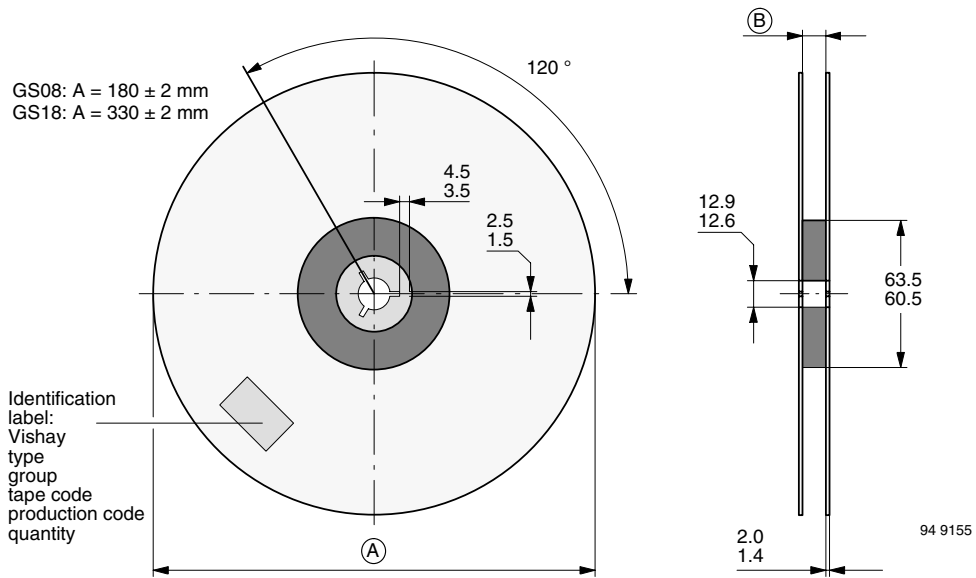

Fig. 5

## MISSING DEVICES

A maximum of 0.5 % of the total number of components per reel may be missing - exclusively at the beginning and at the end of the reel. A maximum of three consecutive components may be missing, provided this gap is followed by six consecutive components (see figure 6).

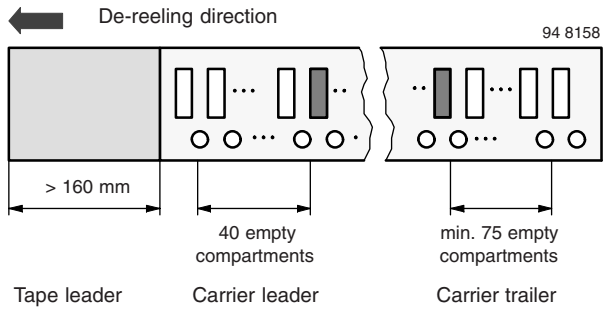

Fig. 6

## LABELING



Fig. 7 - Labeling of Taping Reel



Fig. 8 - Labeling of Carton Box